



Utility Cart and Dri-Cab

Assembly, Operating, and Maintenance Instructions



(Dri-Cab Shown)

Contents	Page#
• Utility Cart Assembly	2
• Dri-Cab Assembly	3-5
• Safety, Operation, and Maintenance	6
• Wiring Diagram	7
• Warranty	8

Vastex International, Inc.
7 Emery St
Bethlehem, Pa. 18015 USA
Phone# 610 625-2702 Fax# 610 625-2775
Web Site www.vastex.com

Authorized Representative in Europe:
 Certification Experts BV
 Nieuwstad 100 1381 CE Weesp,
 The Netherlands
 Tel : + 31 (0) 294 – 48 33 55
 Fax : + 31 (0) 294 – 41 46 87

Vastex E-mail assistance

Purchasing & Product Info:
sales@vastex.com
 Electrical Support:
stech@vastex.com
 Tech Support, Mechanical Setup, and Operation:
techsupport@vastex.com
 Screen Printing Issues & Support:
printech@vastex.com

Serial Number: VTX_____ Date: ___/___/___

(Please log your machine's serial number and date of purchase for future reference.)

Assembly

Tools Needed: (1) Philips Head Screwdriver, (2) 7/16" open end wrench or socket,
(1) Adjustable wrench or 3/4" Open end/Socket Wrench, Tape Measure.

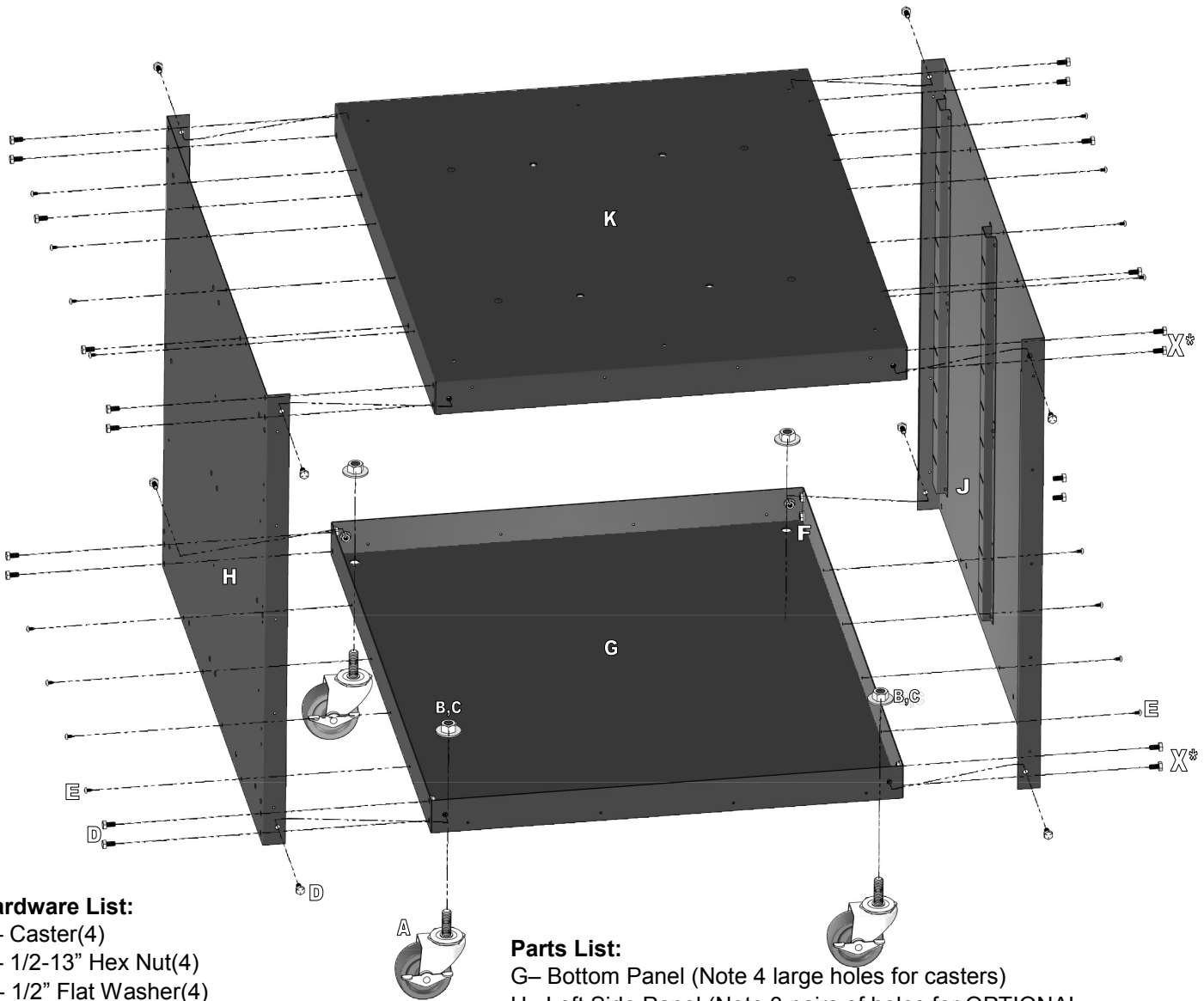

Hardware List:

- A- Caster(4)
- B- 1/2-13" Hex Nut(4)
- C- 1/2" Flat Washer(4)
- D- 1/4-20 x 1/2" Hex Bolt(28)
- E- #8x3/8" Phillips Sht Metal Screw(16)
- F- 1/4-20 Serrated Nuts(28)

Parts List:

- G- Bottom Panel (Note 4 large holes for casters)
- H- Left Side Panel (Note 3 pairs of holes for OPTIONAL Dri-Cab Hinge)
- J- Right Side Panel
- K- Top Panel (Note 2 Braces running side to side)

Procedure

- 1) Install all 4 Casters(A) onto bottom Panel(G). Tighten nuts well with adjustable wrench or 3/4" Socket.
- 2) Install all other hardware (refer to diagram above) Leave hardware loose for now.
- 3) *For DRI-CAB Assembly, do not install (4) 1/4-20 x 1/2" Hex bolts (X) yet, save for hinge install.

Assembly (Cont'd)

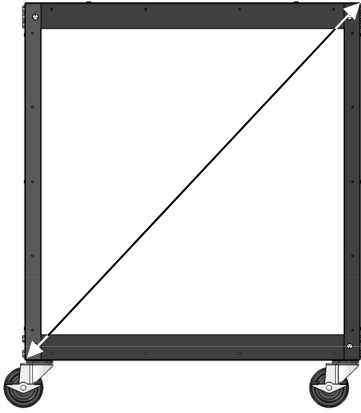

4) Make sure Utility Cart is square by making these two dimensions equal. Use a tape measure or ruler to verify.

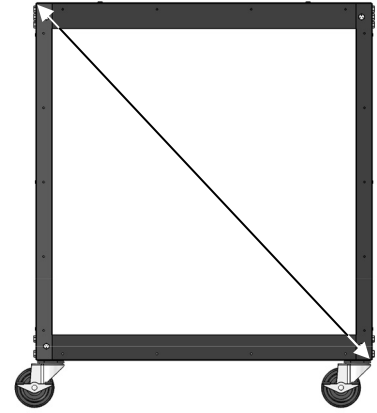

5) Tighten all Installed hardware.

- Use 7/16 wrenches or sockets to tighten 1/4-20 Hardware.
- Use a Phillips head screwdriver for Sheet metal screws

6) Install **Screen Shelves as shown below, start from bottom.

**UC-1000 has 10 shelves, UC-1000-1 has 20 shelves and VDC-2331 has 20 shelves.

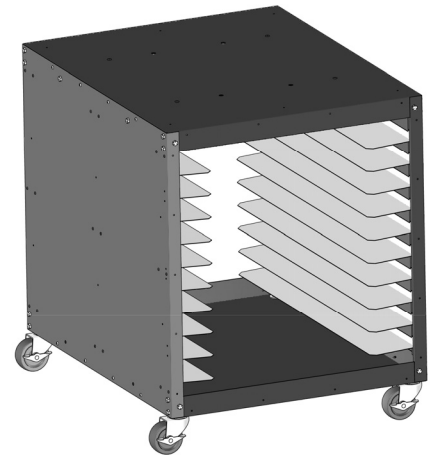
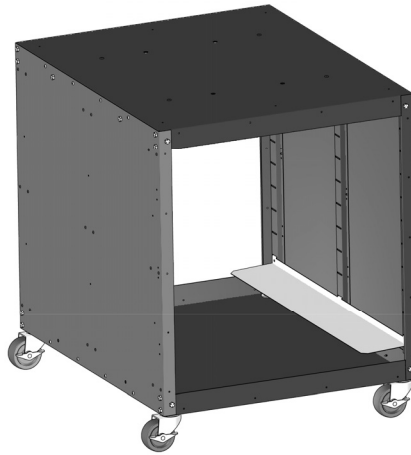
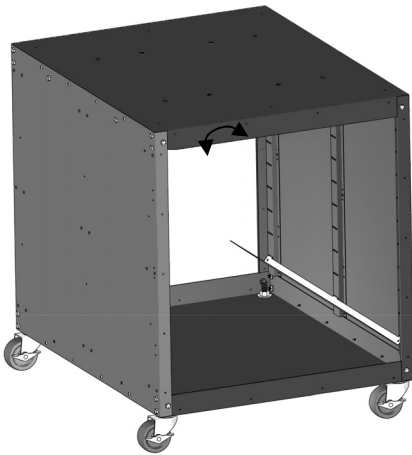

5) Utility Cart Assembly Finished.

Please continue for Dri-Cab Assembly

Dri-Cab Assembly

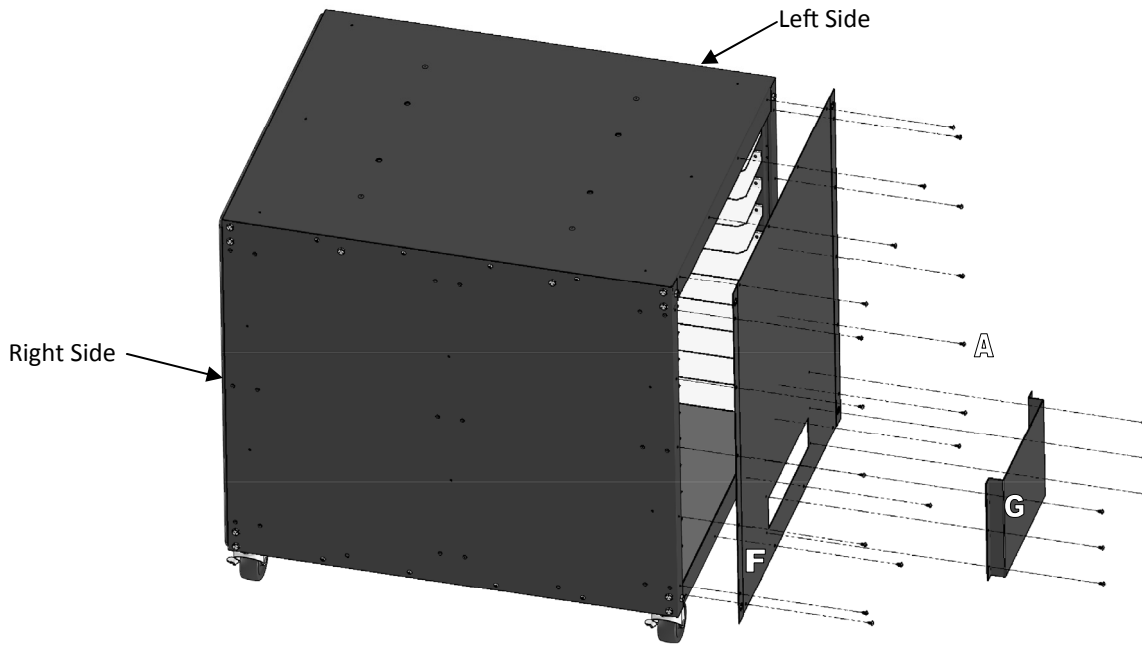

Hardware List:

- A- #8x3/8" Phillips Sht Metal Screw(24)
- B- 4-40 x 5/8" Phillips Pan Head Bolt(4)
- C- 4-40 Hex Nut w/ star washer(4)
- D- #8 x 3/8" Sheet Metal Screw-Blunt tip(10)

Parts List:

- F- Back Panel
- G- Diffuser
- H- Hinge Bracket- Door
- J- Door
- K- Deep Handle
- L- Door Latch

- 1) Install Back Panel, Diffuser, Hinge Brackets-door as shown using a Phillips Head Screw Driver.
- 2) Install Deep Handle using a 1/4" nut driver or Flat blade screw driver.
- 3) Install Door Latch pieces using a 1/4" nut driver or Flat blade screw driver. Leave these slightly loose until door is aligned to body.

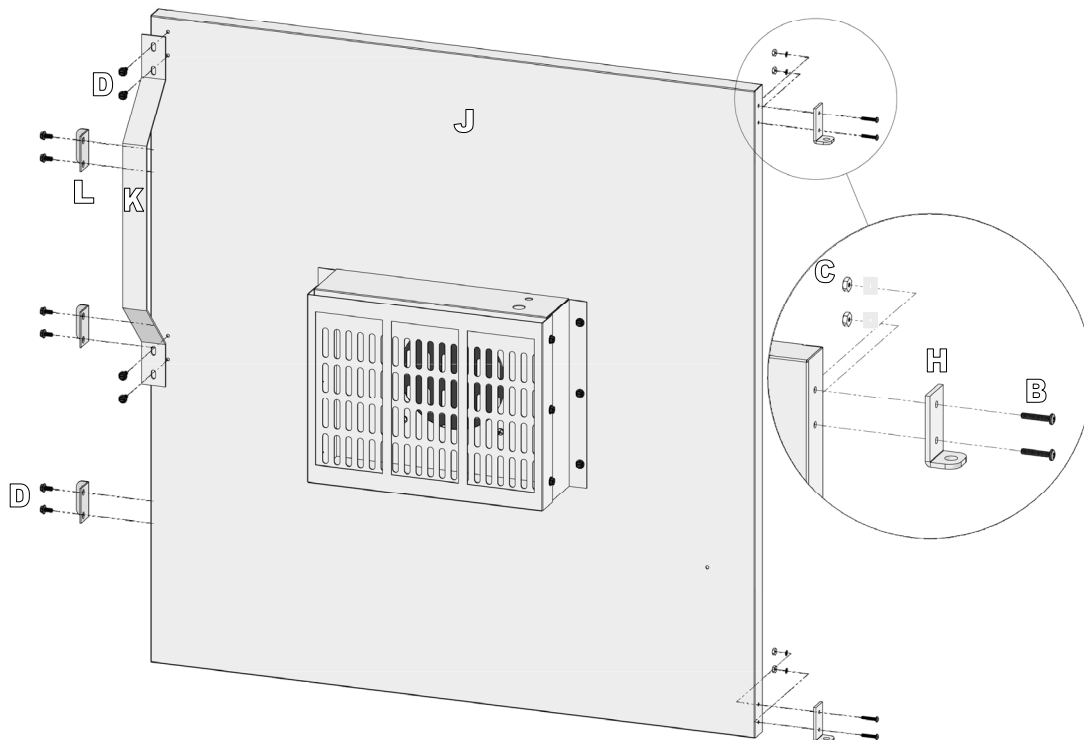

Dri-Cab Assembly cont'd

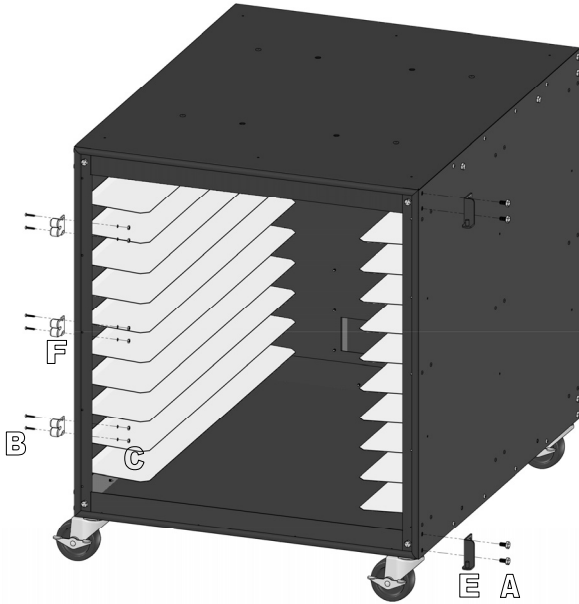

4) Install Hinge Brackets using 1/4-20 bolts and Serrated nuts. Leave this slightly loose until door is aligned.

5) Install (3) Catches using #4 bolts and nuts. Leave this slightly loose until door is aligned.

6) Install 4 pieces of rubber seal around front outside edge of cabinet. Overlap the seal in the corner and cut through both, on a 45, using a sharp knife, to create a sealing corner.

Hardware List:

- A- 1/4-20x1/2" Hex bolt(4)
- B- 4-40 x 5/8" Phillips Pan Head Bolt(6)
- C- 4-40 Hex Nut (6)

Parts List:

- E- Hinge Bracket (Body)
- F- Catch
- G- Seal

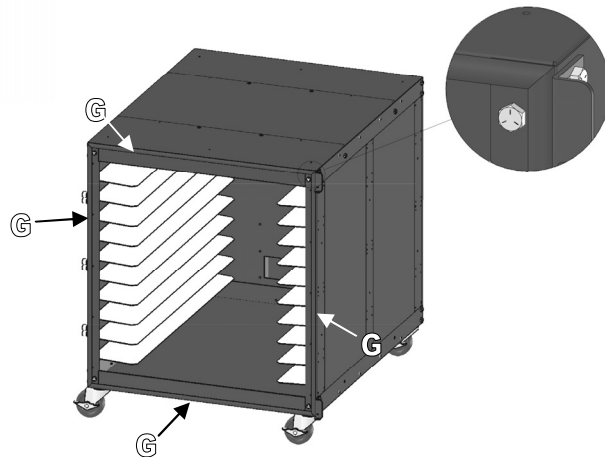

7) Hang Door on Hinge Brackets as shown.

8) Adjust Hinge Brackets and Catch until the Dri-Cab Door slightly squishes the seal when the door is closed. If needed, Latches can be adjusted vertically.

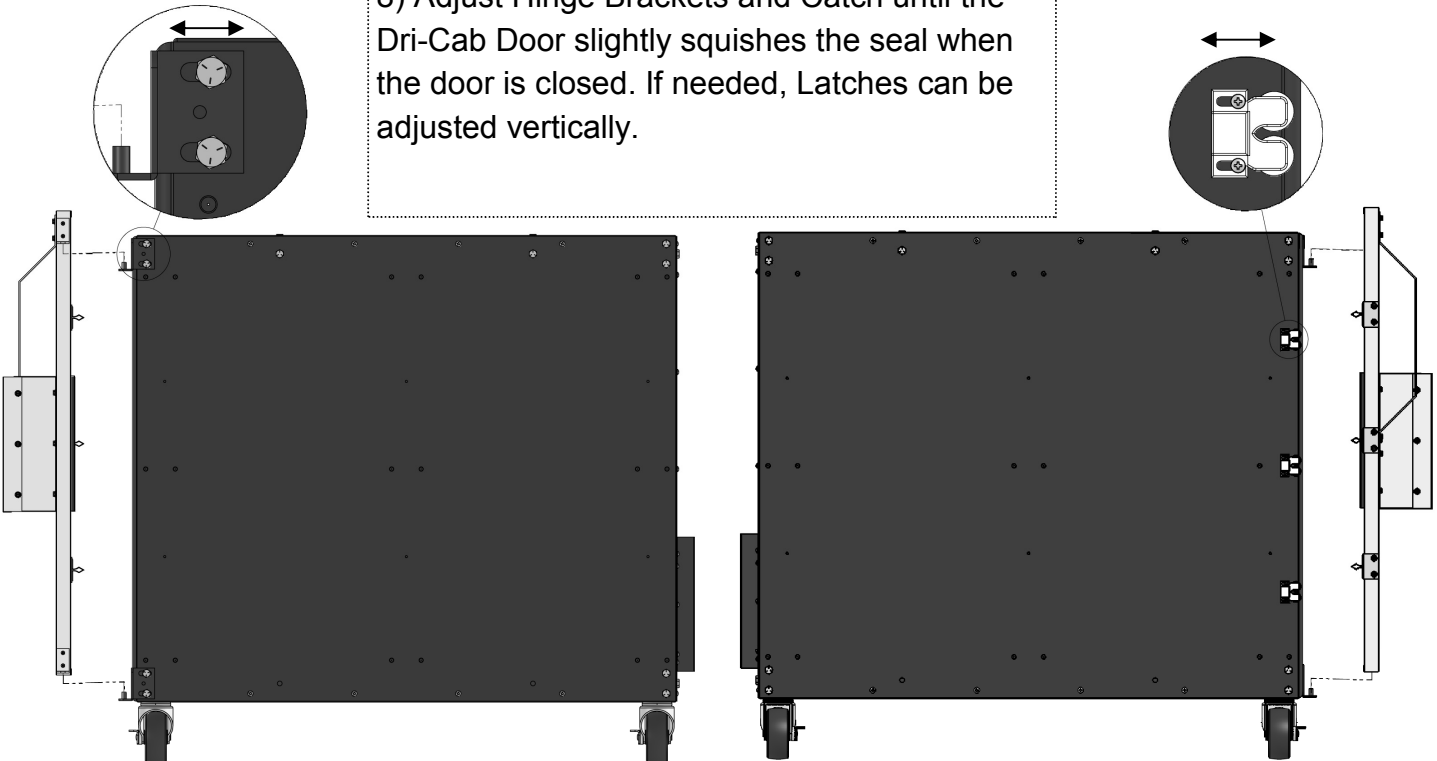

Safety Instructions

- The operator should read and understand the instruction manual before operating this equipment. Store instruction manual and safety instructions near equipment for easy access to operators.
- VASTEX Screen Drying Cabinet is intended for the drying of emulsion on screen printing screens. Do not use for any other purpose unless authorized by Vastex International, Inc. Use of this equipment for any other purpose can be dangerous and may cause damage to this equipment voiding the warranty.
- It is recommended that the area around this equipment be designated as a work area and only authorized employees are allowed in this area.
- Children and pets must be kept clear from the work area.
- Never leave equipment unattended.
- DO NOT operate dry cabinet with any cover or guard removed.
- Operator must be familiar with controls of the dryer.
- Before starting production, the operator must check that all covers and guards are in place, no material has been left in the cabinet, and the exhaust duct is clear of any obstructions.
- Always turn off power at the main disconnect at the end of production.
- Do Not remove any cover or guard until power at the main disconnect is switched off and locked out. No unauthorized persons are to be allowed inside the control boxes.
- Turn off and lock out power at the main disconnect before cleaning and maintenance.
- Only qualified technicians should be allowed to make repairs on the VASTEX Screen Drying Cabinet.
- **Noise and Vibration: This noise level produced by this equipment does not exceed 70 dB(A).**

Operation

- 1) Before using the dry cabinet, make sure the inside is thoroughly **clean** and **dust free**. Never operate with dirty or missing intake filter.

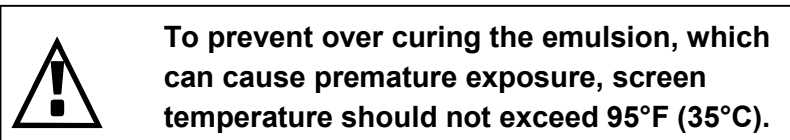

- 2) Turn on the power switch, make sure fan is operating. Leave the unit on until the screens are dry. It will take approximately 40-60 minutes to dry a fully loaded cabinet of coated screens. The actual time will depend on the humidity level in your room. A dehumidifier is recommended for better screen development.
- 4) Once the screens are dry, turn off the power switch. The screens can be stored in the cabinet until needed.

Maintenance

- 1) Every week, the intake filter should be checked and cleaned as needed. A dirty filter reduces air flow thru the cabinet and will alter the drying process. The filter should be replaced as necessary. Filter material can be ordered through Vastex.
- 2) It is important that the inside of the dry cabinet is kept clean. Periodic cleaning of the inside of the cabinet is recommended.
- 3) Check the exhaust for debris and clogging. Any restriction in the exhaust will alter the drying process.

LEGEND

DESCRIPTION	PART NO.	USED ON
CORDSET	04-03-013	120 VOLT
CORDSET	04-03-149	240 VOLT EU
CORDSET	04-03-210	240 VOLT UK
FAN	04-02-064	120 VOLT
FAN	04-02-063	240 VOLT
LIGHT MAIN POWER	04-03-021	ALL
SWITCH SYSTEM	04-01-115	ALL

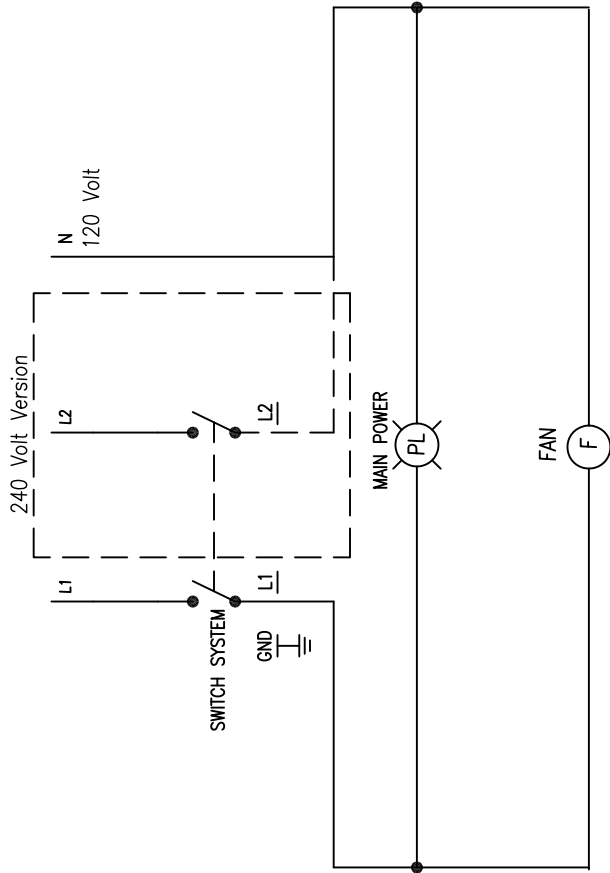

TOLERANCES UNLESS OTHERWISE SPECIFIED		TITLE:	
.XXX	.XX	VDC-2331 DRI-CAB WIRING DIAGRAM	
DECIMAL	±0.015	±.032	
FRACTION	±1/16		
ANGLE	±1°		
125		SIZE	DRAWING NO.
125		C	02-08-011
APPROVED		SCALE: NONE	
S.J.L. 8/19/14		SHEET 1 OF 1	

VASTEX INTERNATIONAL

VDC-2331 DRI-CAB WIRING DIAGRAM

REV: -

02-08-011

SHEET 1 OF 1

Vastex Warranty

Doc#01-00-005C Revised 10/15/2015

(1.) Vastex, hereinafter referred to as "seller" warrants only to its original "purchaser", who holds a copy of the original invoice and is the original end user of the equipment in question, its new equipment against manufacturer defects in materials or workmanship on a pro-rated basis. Warranty period begins from date of shipment to the buyer and will only apply to customers paid in full. Warranty periods are as follows: one (1) year for E-1000, three (3) years for all other complete machines (including F-Flash), fifteen (15) years for infrared heaters (excluding F-Flash) installed by Vastex in a new dryer, three (3) years for replacement infrared heaters, and one (1) year for replacement parts. Rubber blankets, light bulbs and glass on exposure units are particularly subject to wear while in use. Wear is not covered by this warranty but as stated above only manufacturers defects are covered. All sales made through Vastex dealers must be certified by that dealer before a warranty replacement is issued. All equipment is thoroughly tested and inspected before packaging. This warranty does not cover minor cosmetic damages that occur during shipment that do not affect the functionality of the equipment.

(2.) **This warranty is expressly contingent upon the buyer delivering to seller, at the address below, with all transportation charges prepaid, the part or parts claimed to be defective within the above mentioned warranty periods stated in paragraph one. The defective part or parts will be repaired or replaced at the discretion of Vastex International, Inc. If the equipment in question is less than one (1) year old, it will be shipped to the customer at no charge, with an RGA issued by Vastex for the defective part. The defective part must be shipped back to Vastex freight prepaid within 30 days or the account will be billed. If the equipment is more than a year old, the part will be shipped after we receive the defective part. If it's necessary to expedite the movement of parts and to minimize down time to the buyer, the replacement part shall be supplied on a C.O.D. basis. If testing and analysis of said part by the seller or its supplier discloses that said part is defective, the cost of said part will be refunded to the buyer on a prorated basis.**

(3.) Except as otherwise provided herein, the equipment is being sold "as-is". Final determination of the suitability of the equipment for the use contemplated by the buyer, is the sole responsibility of buyer, and seller shall have no responsibility in connection with the suitability.

(4.) All warranties implied by law, including the implied warranties of merchantability and fitness are hereby limited to manufacturer defects in materials or workmanship during the warranty period stated in paragraph one. The express warranty and remedies contained herein and such implied limited warranties are made solely to the sole warranties and remedies and are in lieu of all other warranties, guarantees, agreements, and other liabilities, whether express or implied, and all other remedies for breach of warranty or any other liability of seller, in no event shall seller be liable for consequential damages.

No person, agent, distributor, or service representative is authorized to change, modify or extend the terms hereof in any manner whatsoever.

These terms and conditions are an essential part of the transaction between the parties and constitute the entire agreement between them with respect to the same.

Some states do not allow limitation on how long an implied warranty lasts of the exclusion or limitation of incidental, or consequential damages, so the above limitation may not apply to you.

This warranty gives you specific legal rights, and you may also have other rights which vary from state to state.

Infrared heaters are the only replacement parts covered for a period of (3) years from date of shipment and contingent to receipt of payment in full.

Electrical components cannot be returned once installed unless proven defective.

Please refer to doc. 01-00-015 for specific terms and conditions of sale and the limited warranty.

Please refer to doc. 01-00-017 for V-2000HD printer warranty.

Updates: V1000 to 3 year warranty 01/09/12, Heater warranty to 15 years 01/02/2012.

TERMS AND CONDITIONS OF SALE AND LIMITED WARRANTY Doc.#01-00-015

1. Buyer's order will constitute an offer in accordance with the terms hereof and such offer, upon acknowledgment of Seller, will constitute the agreement between Buyer and Seller. Buyer's order after such acknowledgment by Seller will not be subject to cancellation, change or reduction in amount, or suspension by Buyer of deliveries, unless prior to such action Buyer has obtained Seller's written consent. Notwithstanding anything to the contrary in Buyer's Purchase Order or other communications, the parties agree to be bound by these Terms and Conditions. Acceptance of the product by the Buyer shall be deemed to constitute unconditional acceptance of these Terms and Conditions.
2. Any of these terms, conditions and provisions of Buyer's order which are inconsistent with Seller's acknowledgment and these Terms and Conditions of Sale shall not be binding on the Seller and shall be considered not applicable to any sale so made. No waiver, alteration or modification of any of the provisions on either side of the document shall be binding upon Seller unless agreed to in writing by Seller.
3. (a) All prices are F.O.B. Seller's Plant and method of delivery and routing shall be at Seller's discretion, unless specifically otherwise stated herein. Notwithstanding any agreement to pay freight, delivery of products purchased hereunder to a common carrier or licensed trucker shall constitute delivery to Buyer and be determinative of the date and time of shipment and all risk of loss or damage in transit shall be borne by Buyer. If the Buyer fails to accept the goods from the common carrier or licensed trucker, the Seller shall be entitled to claim payment from the Buyer. Seller shall arrange for storage, the risk and the cost, including insurance costs, to be borne by the Buyer (and Buyer agrees to pay such amounts upon demand) except if the failure to accept delivery is due to any of the exceptions noted in Paragraph 4.
(b) Terms of payment shall be as stated on invoice.
4. It is understood that deliveries will be made in accordance with Seller's regular production schedule. Every reasonable effort will be made to meet the Buyer's required delivery dates but Seller will not be liable for damages or be deemed to be in default by reason of any failure to deliver or delay in delivery due to any preference, priority, allocation or allotment order issued by the Government, whether Federal, State or local, or causes beyond its control including but not limited to, Acts of God or a public enemy, acts of Government, fires, floods, epidemics, quarantine restrictions, strikes, lockouts, freight embargoes, severe weather, unavailability of materials or shipping space, delays of carriers or suppliers or delays of any subcontractors. Should delay in delivery be caused by any of the circumstances mentioned in this paragraph, such extension of the delivery period shall be granted as is reasonable under the circumstances of the case. Should delay be caused by an event not specifically mentioned in this paragraph, damages will be limited to cancellation of the purchase order without penalty, and refund of any monies deposited or prepaid on the purchase order with no liability for any consequential or incidental damages.
5. Seller reserves the right to increase the prices prior to Seller's acceptance of order and/or after expiration of any price quoted by Seller.
6. Unless otherwise stated in writing, Seller's prices do not include sales, excise, value-added or other taxes. Consequently, in addition to the price specified herein, the amount of any present or future sales, use, excise, value-added or other tax applicable to the manufacture, sale, purchase or use of the products hereunder shall be paid by Buyer, or in lieu thereof, Buyer shall provide Seller with a valid tax exemption certificate acceptable to the taxing authorities.
7. Seller reserves the right, at any time, to revoke any credit extended to Buyer because of Buyer's failure to pay for any products when due or for any other reason deemed good and sufficient by Seller and in such event, all subsequent shipments shall be paid for prior to at delivery at Seller's option.
8. (a) SELLER'S LIABILITY SHALL BE LIMITED TO SELLER'S STATED SELLING PRICE PER UNIT OF ANY DEFECTIVE GOODS AND SHALL IN NO EVENT INCLUDE BUYER'S MANUFACTURING COSTS, LOST PROFITS, GOODWILL, OR ANY OTHER SPECIAL, INDIRECT, INCIDENTAL OR CONSEQUENTIAL DAMAGES, ARISING OUT OF THE AGREEMENT, THIS CONTRACT, THE SALE OF THE PRODUCTS TO THE BUYER OR THE USE OR THE PERFORMANCE OF THE PRODUCTS. Seller may at its discretion repair, replace or give the Buyer credit (pro-rated) for such defective products.
(b) Notwithstanding anything herein to the contrary, Seller shall have no liability for alleged defects with the products which are not specified in written notice from the Buyer to the Seller within thirty-six (36) months from the date of shipment of machines. Seller shall pass to Buyer any warranty received by Seller from the manufacturer of Limited Life Components, which in most cases is 12 to 18 months.
(c) Seller shall have no liability under this Limited Warranty unless Buyer has paid in full for the products. Further, this Limited Warranty is expressly contingent on Buyer's delivery to Seller, all costs prepaid, the defective part(s) within thirty-six (36) months of shipment to Buyer, together with a written statement specifying the alleged defect(s). Any replacement part(s) shall be shipped to Buyer on a C.O.D. basis.
(d) SELLER SPECIFICALLY EXCLUDES ALL WARRANTIES, EXPRESSED, IMPLIED OR OTHERWISE, EXCEPT AS STATED EXPLICITLY IN THESE TERMS AND CONDITIONS OF SALE. SELLER DISCLAIMS THE WARRANTY OF MERCHANTABILITY AND FITNESS FOR A PARTICULAR PURPOSE.
9. The remedies herein reserved by Seller shall be cumulative and in addition to any other legal remedies. No waiver of a breach of any portion of this contract shall constitute a waiver of continuing or future breach of such provision or of any other provisions hereof.
10. These Terms and Conditions constitute the entire agreement of the parties. No amendments, changes, revisions or discharges hereof in whole or in part shall have any force or effect unless set forth in writing and signed by the parties hereto. This contract shall not be assignable by Buyer voluntarily by operation of law or otherwise without Seller's written consent.
11. This contract shall be governed and shall be construed according to the domestic laws of the Commonwealth of Pennsylvania.
12. Anything herein to the contrary notwithstanding, any action for alleged breach by Seller of the contract between the parties, including but not limited to any action for breach of the warranties herein set forth, shall be barred unless commenced by Buyer within one (1) year from the date such cause of action accrued.
13. This agreement shall inure to the benefit of and be binding upon the parties hereto, their respective successors and permitted assigns.
14. **All notices required by this contract to be given by either party shall be sent in writing or by facsimile and shall be addressed to the last known address of such other party. Notices shall be deemed to have been received on the fifth business day following deposit in the mail.**

VASTEX
INTERNATIONAL

1032 N. IRVING ST.
ALLENTOWN PA. 18109 USA